

FOR OFFICIAL USE

--	--	--	--	--	--

G

Q1		Q5	
Q2		Q6	
Q3		Q7	
Q4			

Total

--

0600/402

NATIONAL
QUALIFICATIONS
2010

MONDAY, 17 MAY
10.20 AM – 11.20 AM

CRAFT AND DESIGN
STANDARD GRADE
General Level

Fill in these boxes and read what is printed below.

Full name of centre

--

Town

--

Forename(s)

--

Surname

--

Date of birth

Day Month Year

--	--	--	--	--	--

Scottish candidate number

--	--	--	--	--	--	--	--	--	--

Number of seat

--

- 1 Answer all the questions.
- 2 Read every question carefully before you answer.
- 3 Write your answers in the spaces provided.
- 4 Do **not** write in the margins.
- 5 All dimensions are given in millimetres.
- 6 Before leaving the examination room you must give this book to the Invigilator. If you do not, you may lose all the marks for this paper.



ATTEMPT ALL QUESTIONS

1. A rocking horse is shown below.



(a) The rocking horse is made from a softwood.

State the name of a suitable softwood.

1
0

(b) Two joints used in the manufacture of the rocking horse are shown below.
State the name of each joint.

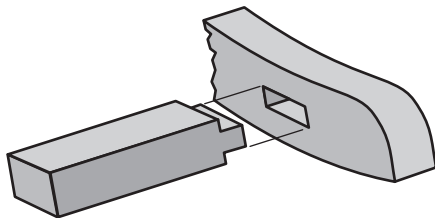

Name _____

1
0

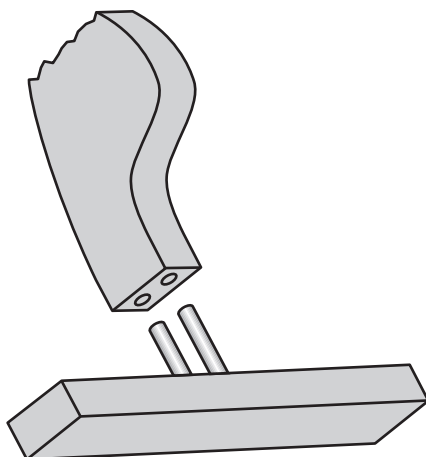

Name _____

1
0

1. (continued)

- (c) A butt joint was considered for joining the leg to the cross rail as shown.

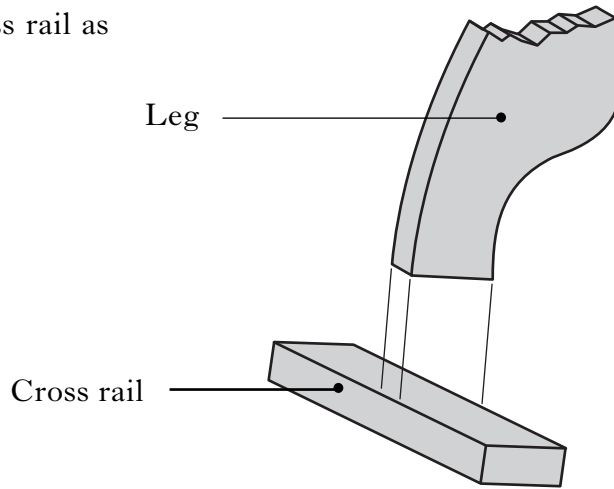

State **one** reason why this joint was rejected.

1
0

- (d) The following tools were used in the manufacture of the rocking horse. State the name of each tool.

(i)

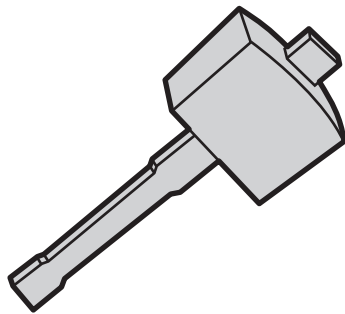

Tool _____

1
0

(ii)

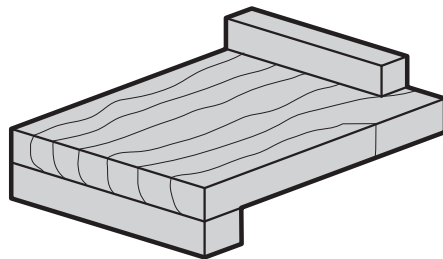

Tool _____

1
0

(iii)

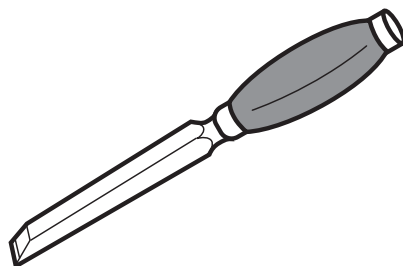

Tool _____

1
0

2. A table lamp is shown below.



(a) One statement in the specification for the table lamp is given below.

- The body of the lamp must be made from mild steel.

List two other statements that could appear in the design specification.

(i) _____

(ii) _____

(b) The body is made from mild steel.

State a reason for this choice of material.

(c) The sketch below shows the body marked out on the mild steel.

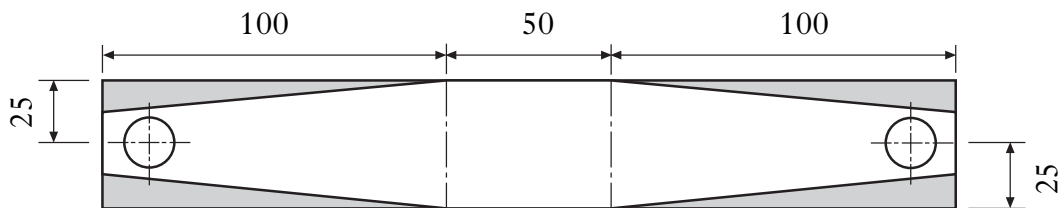

State the minimum amount of material required to manufacture the body.

Length of material _____

Width of material _____

1
0
1
0

1
0

1
0
1
0

2. (continued)

- (d) (i) A scribe rather than a pencil was used to mark out the lamp on the mild steel.

State a reason for using a scribe rather than a pencil.

1
0

The tools shown below were used during the manufacture of the lamp.
State the name and purpose of each tool.

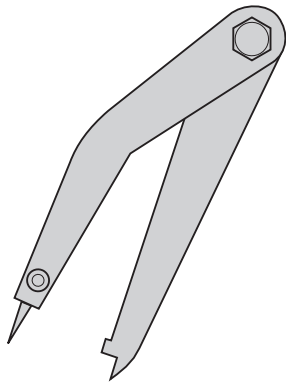

(ii) Name _____

(iii) Purpose _____

1
0

1
0

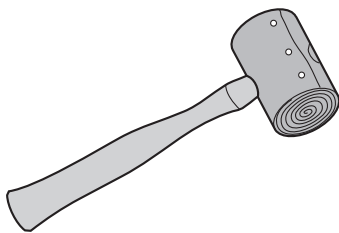

(iv) Name _____

(v) Purpose _____

1
0

1
0

- (e) A finish was applied to the mild steel body.

- (i) State **two** reasons for applying a finish to the mild steel body.

1 _____

2 _____

1
0

1
0

- (ii) After manufacture the lamp was tested and it was found to scratch the surface it was sitting on.

State the stage in the design process when this fault showed up.

1
0

[Turn over

3. A pencil holder is shown below.

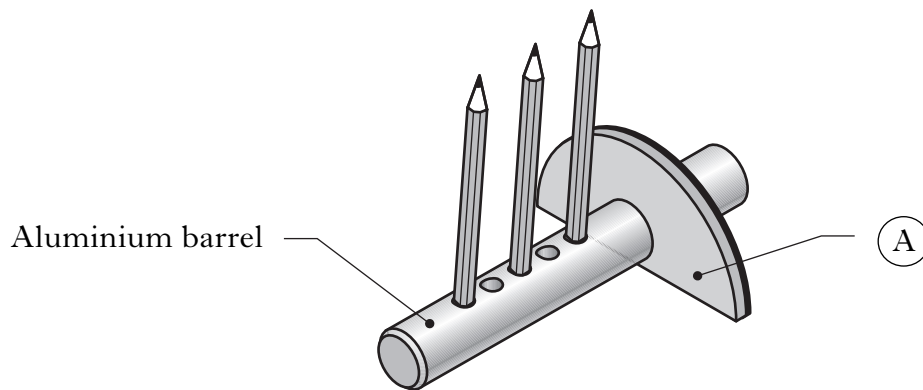

(a) State the function of part (A).

1
0

(b) Aluminium was selected for the barrel of the pencil holder.

State a reason why aluminium makes a suitable choice of material for the barrel.

1
0

(c) The aluminium barrel was cut into two parts using a hand tool.

State the name of a suitable tool.

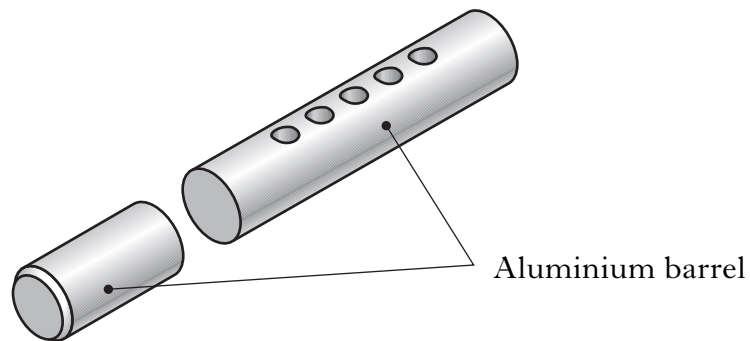

1
0

3. (continued)

(d) The barrel was manufactured on the metal lathe, shown below.

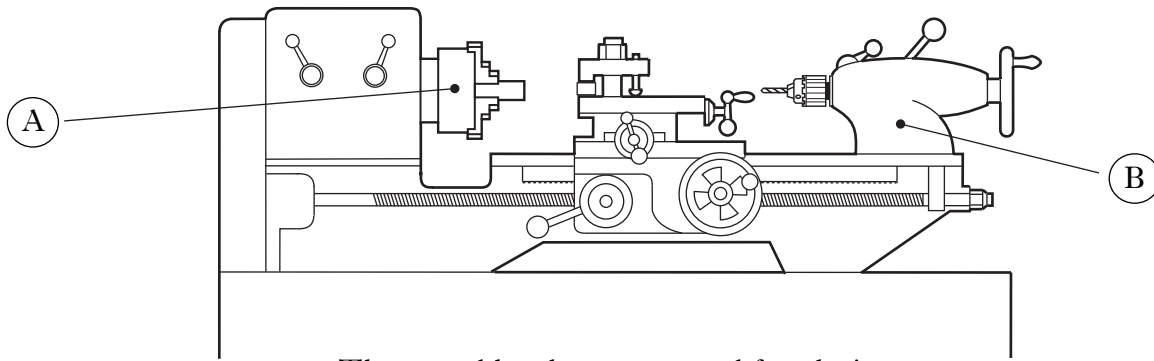

The guard has been removed for clarity

(i) State the name of part (A).

1
0

(ii) State the name of part (B).

1
0

(e) State **two** safety checks that should be observed when using a metal lathe.

1 _____

1
0

2 _____

1
0

(f) Three steps in the manufacture of the barrel are shown.

Name the turning process at (X) and (Y) and the drill used in (Z).

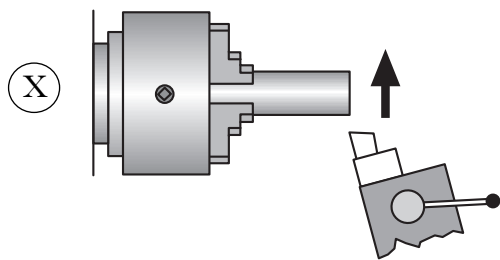

Name of process _____

1
0

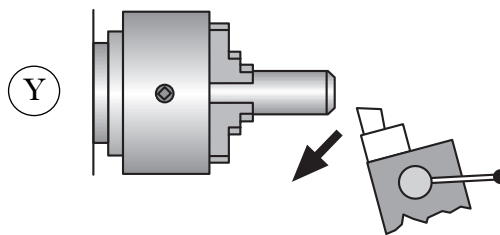

Name of process _____

1
0

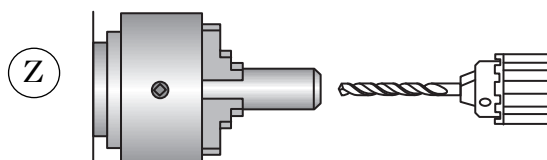

Name of drill _____

1
0

4. A kitchen roll holder is shown below.

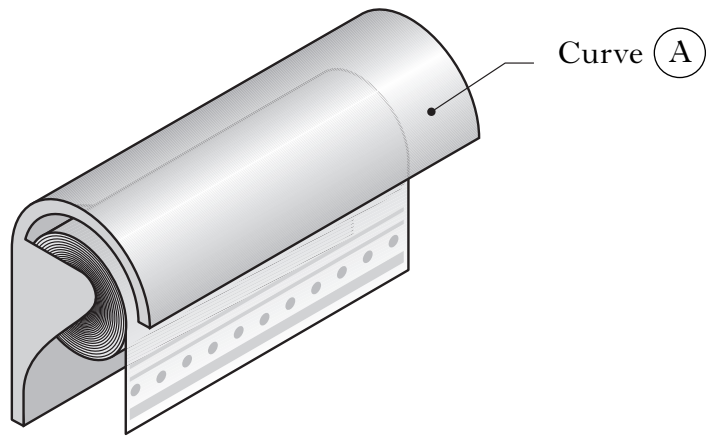

(a) During the design process, the following design factors were considered.

Materials Safety Aesthetics Function Environment

Complete the diagram below by using the **word bank** above.

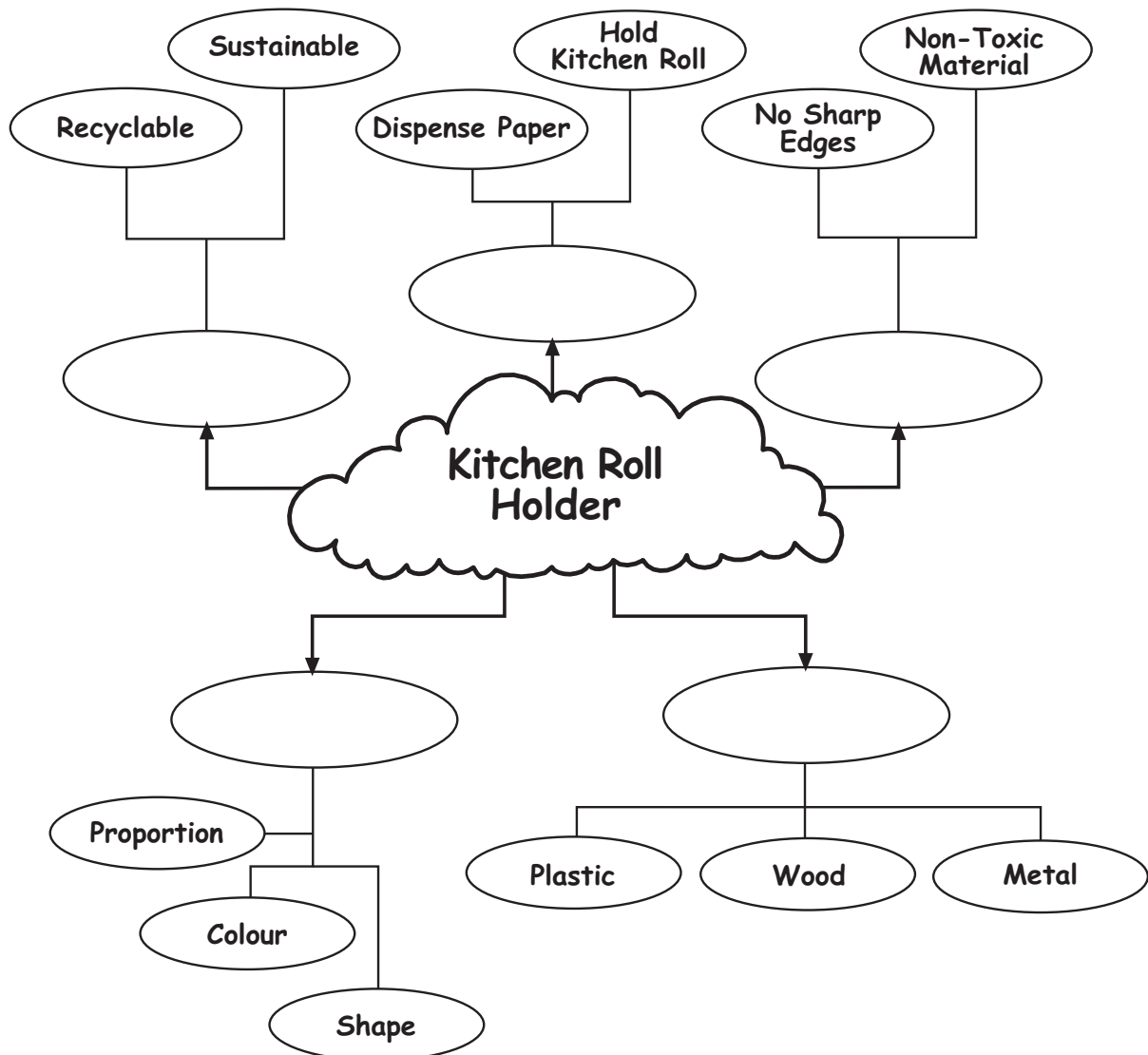

1
0
1
0
1
0
1
0
1
0

4. (continued)

- (b) The kitchen roll holder was made from a thermoplastic.
State the name of a suitable thermoplastic.

The plastic is marked out as shown below.

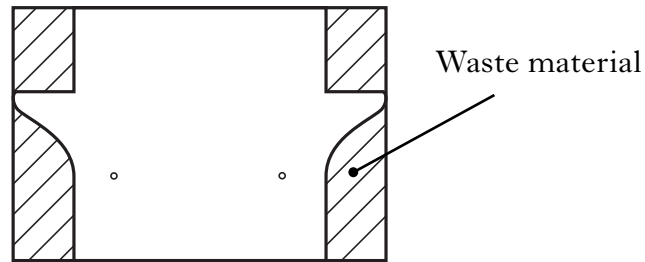

- (c) (i) Select from the list below the name of the equipment used to hold the plastic, while cutting the outline of the holder.

Bench vice G-clamp Hand vice Sash cramp

Name of equipment

- (ii) The holder was cut out using the saw shown below.

State the name of this saw.

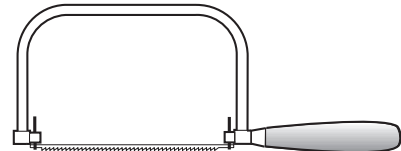

- (iii) Complete the stages for finishing the edges of the plastic.

1 cross file down to the marked line

2 _____

3 use wet and dry paper

4 _____

- (iv) The plastic was heated before the curve at (A) was produced.

State the name of the piece of equipment used to heat the plastic.

1
0

1
0

1
0

1
0

1
0

1
0

[Turn over

5. A trophy is shown.

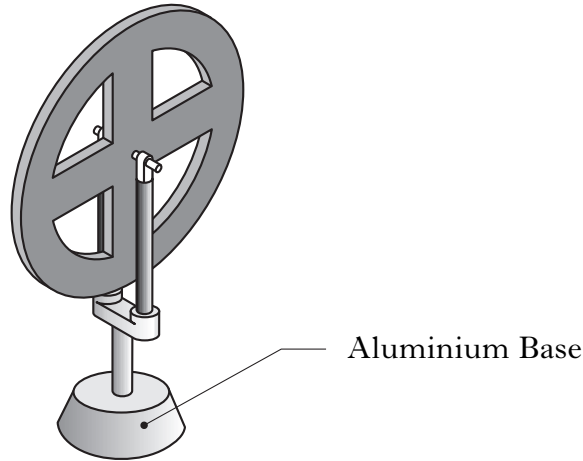

(a) During the manufacture of the base, molten aluminium was poured into a sand mould. Select the name of this process from the list below.

Forging Casting Welding Turning

Name of process

1
0

(b) State a property of aluminium that makes it a suitable material for using this process in schools.

1
0

(c) A cross section of the moulding boxes are shown below.

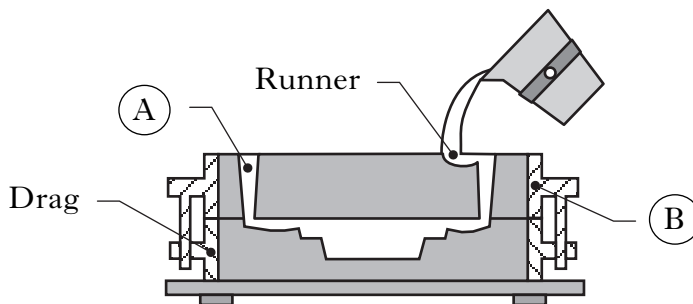

(i) State the name of the opening at (A) .

1
0

(ii) State the name of box (B) .

1
0

(iii) State the name of one piece of protective clothing, apart from gloves and facemask that should be worn when pouring molten aluminium.

1
0

6. The thermoplastic dish shown below was made for a school food and drinks challenge.

Dish

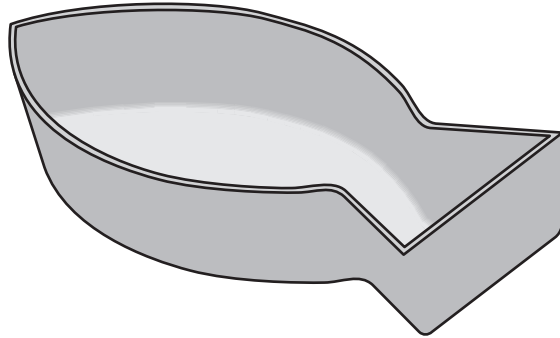

- (a) The thermoplastic was heated and formed to produce the dish shown.
State the name of the process used to produce the dish.

1
0

- (b) The wooden pattern shown below was used during the manufacture of the dish.

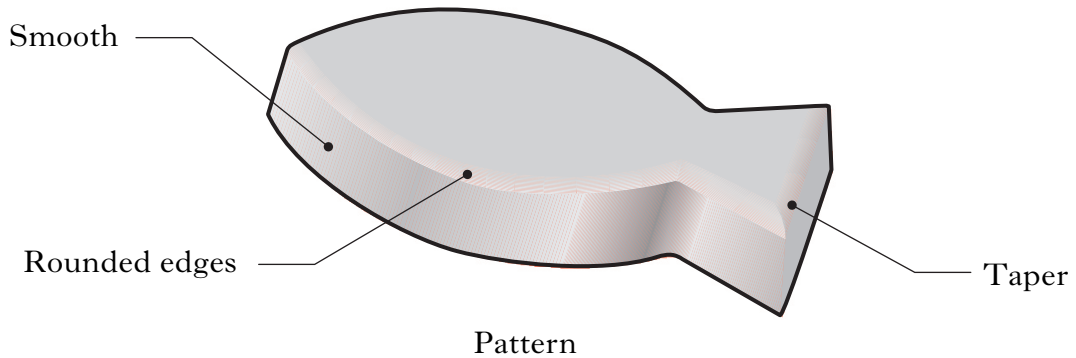

State which feature on the pattern would:

- (i) prevent the plastic from tearing;

1
0

- (ii) help with the removal of the dish from the pattern.

1
0

[Turn over

7. A toothbrush holder is shown below.

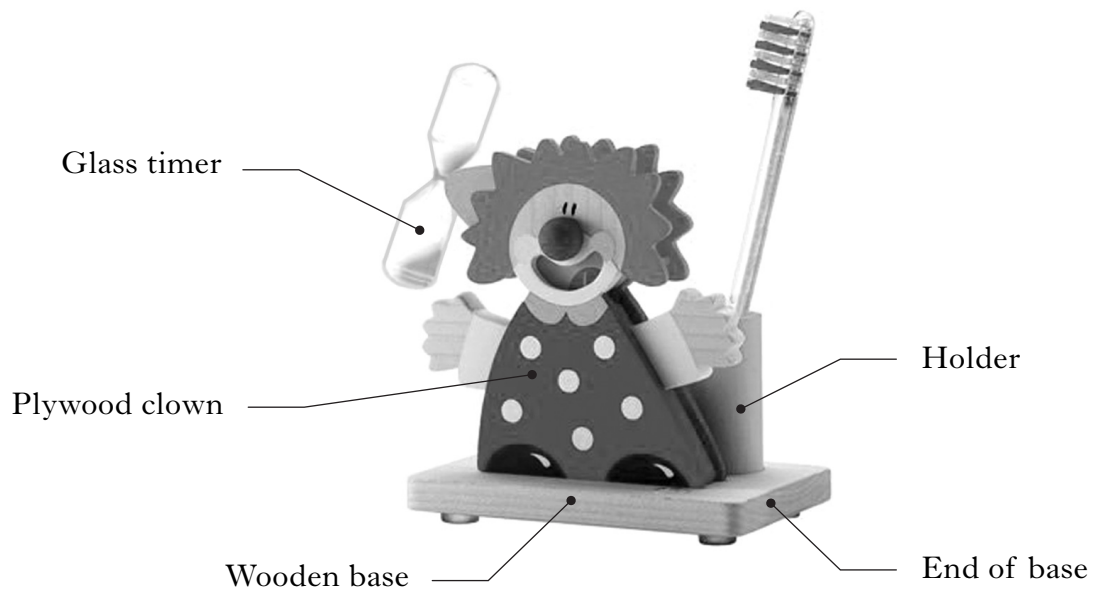

(a) A timer is shown in the design of the toothbrush holder.
State a reason for the timer.

1
0

(b) An incomplete materials research table is shown below.

Ferrous Manufactured board Thermoplastic
Hardwood Non-ferrous

Using the list above complete the table shown below.

Material	Classification	Description
Mild steel		Magnetic, tough
Plywood		Multi-layered board
Mahogany		Close grained, reddish brown in colour
Acrylic		Available in many colours can be heated and shaped
Aluminium		Lightweight, silver coloured

1
0

1
0

1
0

1
0

1
0

7. (continued)

(c) During the design process a working drawing was produced.

State **one** piece of information you would find from a working drawing.

1
0

(d) A machine was used to smooth the ends of the wooden base.

State the name of a suitable machine.

1
0

(e) State the name of a **hand tool** and a **machine tool** that could be used to cut out the plywood clown.

(i) Hand tool _____

1
0

(ii) Machine tool _____

1
0

(f) The client stated that the toothbrush holder was to be finished in primary colours.

State a reason for using primary colours.

1
0

[END OF QUESTION PAPER]

[BLANK PAGE]

[BLANK PAGE]

[BLANK PAGE]