



**2010 Craft & Design**

**Standard Grade F/G/C**

**Finalised Marking Instructions**

© Scottish Qualifications Authority 2010

The information in this publication may be reproduced to support SQA qualifications only on a non-commercial basis. If it is to be used for any other purposes written permission must be obtained from the External Print Team, Centre Services, Dalkeith.

Where the publication includes materials from sources other than SQA (secondary copyright), this material should only be reproduced for the purposes of examination or assessment. If it needs to be reproduced for any other purpose it is the centre's responsibility to obtain the necessary copyright clearance. SQA's External Print Team, Centre Services, at Dalkeith may be able to direct you to the secondary sources.

These Marking Instructions have been prepared by Examination Teams for use by SQA Appointed Markers when marking External Course Assessments. This publication must not be reproduced for commercial or trade purposes.

## 2010 Craft and Design

### Standard Grade – Foundation

#### Marking Instructions

##### Acceptable answers

1. (a) Fourth tick box (It is strong)
  - (b) Flat file  
Ball Pein hammer  
Junior hacksaw
  - (c) Second tick box
  - (d) (i) Third tick box (Fluidiser)  
(ii) Clean metal  
Leave to cool
2. (a) Fault 1 Sharp points on end/sharp edges  
Fault 2 Neck too thin/snap easily  
Any answer which reflects these points
  - (b) (i) First tick box (It is easy to clean)  
Fifth tick box (It bends easily when heated)
  - (ii) Third tick box (Acrylic)
- (c) (i) Any of the following:
  - faster
  - saves time
  - they all turn out the same
  - more accurate etc.
  - (ii) First tick box (Coping saw)
- (d) First stage – Cross file  
Last stage – Apply abrasive polish
- (e) Fourth tick box (Strip heater)

##### Unacceptable answers

how it looks

**Acceptable answers**

- 3. (a)** Third tick box (Plywood)
- (b)** (i) Woodwork Lathe OR Wood Lathe; Lathe
- (ii) Third tick box (Turning)
- (iii) Any two of the following:
- wearing goggles/safety glasses
  - loose hair/clothing tied back
  - work securely fixed
  - no distractions when using machine
  - no button pupils/only one person operates the machine
  - no wearing rings, necklaces, jewellery
  - speed of the machine
  - dust extraction switched on
  - any other acceptable answer.
- (iv) Second tick box
- (v) Second tick box (Checking sizes)
- (c)** (i) First tick box (Bandsaw)
- (ii) First tick box (Forstner)
- (d)** Finish – Acrylic paint
- 4. (a)** Material: Softwood
- Thickness: 12
- Length: 318
- (b)** (i) First tick box (Pine)
- (ii) Housing
- Lap
- (c)** (i) Pedestal drill/Pillar drill/Bench drill
- (ii) First tick box (Material is secured)
- Third tick box (Guard is down)
- Sixth tick box (Chuck key is removed)
- (iii) Prevents plastic from cracking or splitting  
Protects the table on drill
- (iv) Prevents plastic from being scratched

**Unacceptable answers**

wearing gloves  
keep hands away

drill (on its own)

**Acceptable answers**

- 5. (a)** Third tick box (Research)
- (b)** (i) Third tick box (Dowel joint)  
(ii) Fourth tick box (Marking gauge)
- (c)** (i) PVA  
(ii) Suitable for use in a wet bathroom  
(iii) Damp cloth/paper towel  
Chisel  
Using a steel rule  
(iv) Fourth tick box (Try square)
- (d)** (i) Second tick box  
(ii) Screw driver
- 6. (a)** (i) First tick box (Engineer's square)  
(ii) Third tick box (Centre punch)  
(iii) Second tick box (Tin snips)
- (b)** (i) Centre lathe/metalwork lathe/metal lathe  
(ii) Second tick box (Knurling)
- (c)** Second tick box (Threading)
- 7. (i)** Research  
**(ii)** Specification  
**(iii)** Initial ideas  
**(iv)** Sequence of operations  
**(v)** Evaluation

**Unacceptable answers**

waterproof (on its own)  
bathroom (on its own)

finger

lathe

## 2010 Craft and Design

### Standard Grade – General

#### Marking Instructions

##### Acceptable answers

1. (a) Any softwood
- (b) Mortice and Tenon; Dowel
- (c) Lacks strength; breaks easily; not strong enough
- (d) (i) Mallet  
Carpenters mallet  
Bech mallet
- (ii) Bench hook  
Sawing board
- (iii) Mortice chisel
2. (a) Any suitable statement that refers to design factors eg
- free standing
  - material
  - safety
  - target market
  - ergonomics
  - function
  - aesthetics
  - easy to change bulb
  - any other suitable answer.
- (b) Strong  
Easily bent  
Can be painted  
Flexible  
Heat resistant
- (c) 250 length  
50 width

##### Unacceptable answers

balsa

mortice; tenon

stable

chisel

ferrous metal; safe

**Acceptable answers**

- (d) (i) More visible  
Lines cannot be rubbed off  
Easier to see
- (ii) **Name**  
Odd leg callipers  
Jenny callipers
- (iii) **Purpose**  
Draw/scribe lines *parallel* to an edge  
To find centre of metal
- (iv) **Name**  
Hide mallet  
Raw hide mallet
- (v) **Purpose**  
For bending metal  
Does not mark the metal
- (e) (i) Two distinct reasons:  
Easier to clean  
Protection, aesthetics, colour  
Hides scratches
- (ii) Evaluation

3. (a) Stability; stops it rolling

- (b) Shiny, does not require a finish, looks modern.  
Does not rust; easy to work; easy to drill/machine  
Silver in colour

(c) Hacksaw

- (d) (i) Chuck, three jaw chuck  
Hole for chuck key

(ii) Tail stock

(e) Personnel or machine checks acceptable

- (f) X - facing, facing off  
Y - chamfer, taper  
Z - twist, jobber

**Unacceptable answers**

callipers

mallet

aesthetics

lightweight; weight

junior hacksaw

jacobs chuck

**Acceptable answers**

**Unacceptable answers**

**4. (a)**

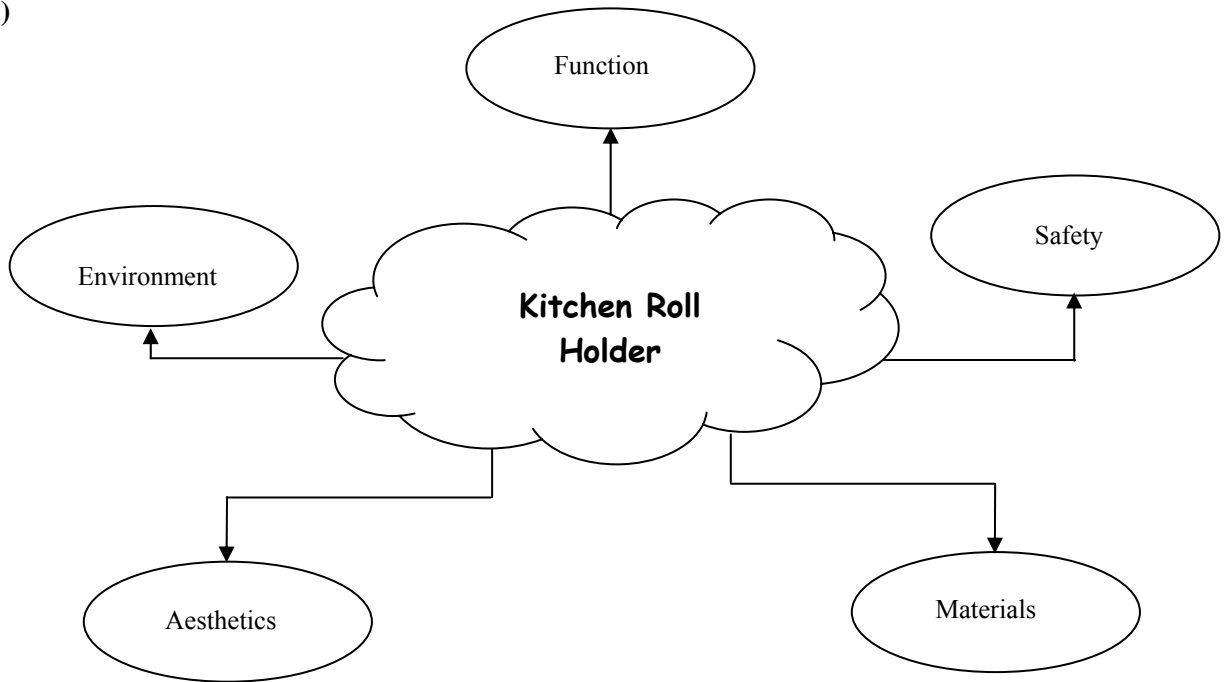

**(b)** Acrylic or any other suitable plastic

**(c)** (i) Bench vice

(ii) Coping saw

(iii) Draw file

Polish; use brasso; steel wool and soap

(iv) Oven

**Acceptable answers**

5. (a) Casting
- (b) Low melting point; melting point
- (c) (i) Riser
- (ii) Cope
- (iii) Spats, leather apron, boots or any other suitable answer
6. (a) Vacuum forming
- (b) (i) Rounded edges
- (ii) Taper
7. (a) Ensure user spends appropriate time brushing teeth, or similar answer
- (b) Ferrous  
Manufactured board  
Hardwood  
Thermoplastic  
Non-ferrous
- (c) Anything from the cutting list is acceptable or details of construction; number of parts; scale; method of construction, joints, materials, sizes
- (d) Sander
- (e) (i) Coping saw; fretsaw; abrafile
- (ii) Hegner or jigsaw or scroll saw or bandsaw  
Fretsaw
- (f) Attractive to young people or it stands out  
Bright; strong colours; contrast; looks nice

**Unacceptable answers**

apron; boiler suit; long coat; goggles

finishes  
what it looks like



## 2010 Craft and Design

### Standard Grade – Credit

#### Marking Instructions

##### Acceptable answers

1. (a) The depth of the blade  
The angle of the blade  
The width of the mouth
- (b) Step 1 – Set the spurs to be 12mm apart  
Step 2 – Set the stock to place spurs centrally
- (c) To raise the grain; bring out the grain
2. (a) Any two of the following:
  - thought shower/brain storming
  - morphological analysis
  - take your pencil for a walk
  - shape manipulation
  - analogies
  - themes
  - moodboard
  - SAM
  - mind maps
  - market research
  - spider diagram
  - existing products.
- (b) Ash, Beech, Mahogany, Oak, or any other suitable hard wood (NOT Balsa)
- (c) Cross halving; halving
- (d) Any of the following:
  - rotate or turn to angle
  - height of the tool rest
  - position along the lathe
  - the distance from the blank
  - remove toolpost
- (e) Gouge, scraper; skew chisel
- (f) Outside callipers
- (g) Increase the speed of rotation on lathe

##### Unacceptable answers

- length of blade
- remove scratches and bumps
- research
- parting tool
- callipers; external callipers
- adjust the speed

**Acceptable answers**

- 3. (a) (i)** To allow easy removal  
Less likely to damage mould on removal
- (ii)** To allow the separation of cope and drag boxes  
To prevent the moulds sticking together  
Easy removal of pattern
- (b)** To allow gases/steam to escape  
To prevent the top mould 'exploding'  
'Vents'; relieve pressure
- (c) (i)** Tapered/rounded end
- (ii)** Die/die holder
- (iii)**
- Loosen the locking screw.
  - Tighten the adjustment 'grub' screws to close split die.
  - Tighten the locking screw.
- (d) (i)** Bends/shapes without fracturing  
Bends and stays in 'bent shape'  
Workable  
Bendable  
Easier to bend
- (ii)** Annealing
- (iii)** It turns black when the aluminium is the correct temperature.
- 4. (a)** Anthropometrics
- (b)** 95<sup>th</sup> percentile
- (c)** The lathe tool is incorrectly positioned, not aligned to the centre of work  
OR  
The tool was not moved far enough along the face of the work
- (d)** Parting tool
- (e) (i)** To give grip; aesthetics
- (ii)** Set the lathe to a slow turning speed

**Unacceptable answers**

'air' to escape

'file' (on its own); lubricant

'stock' (on its own)

adjust screws (on its own)

flexible

normalising

**Acceptable answers****Unacceptable answers**

<b>(f)</b>	(i) Centre drill/Slocomb/Combination drill	
	(ii) To drill pilot hole OR To drill a small hole in the centre of metal	
	(iii) Using the vernier gauge, (ruler), on tail stock Use masking tape	depth stop
<b>(g)</b>	(i) The tap could break if it hits the bottom of the blind hole Strip the thread	
	(ii) Taper tap; 1st tap	
	(iii) Plug tap; bottoming tap	
<b>(h)</b>	Stage 1 Clean metal of rust, oil and dirt	
	Stage 2 Heat metal with temperature control	reheat
	Stage 3 Dip metal into <u>fluidiser</u> and remove and allow to cool	
<b>(i)</b>	The metal was not hot enough when placed in the fluidiser	
<b>5. (a)</b>	Any three of the following:	
	<ul style="list-style-type: none"> <li>• materials</li> <li>• safety</li> <li>• manufacturing techniques</li> <li>• target market</li> <li>• function</li> <li>• maintenance/durability</li> <li>• running costs</li> <li>• economics</li> <li>• environmental concerns</li> <li>• any other suitable answer.</li> </ul>	no sub-categories of aesthetics or ergonomics  size (on its own) angle (on its own)
<b>(b)</b>	(i) Initial ideas; ideas	
	(ii) Presentation drawing/final idea/solution/client or customer drawing	working drawing
<b>(c)</b>	Any of the following:	
	<ul style="list-style-type: none"> <li>• jigs/formers/stencils</li> <li>• templates</li> <li>• batch production techniques</li> <li>• automated machines</li> <li>• mass production</li> <li>• production line.</li> </ul>	robots

**Acceptable answers**

6. (a) (i) Easy to use/comfortable
- (ii) Any two of the following:
- rounded/smooth edges
  - curved shape to fit hand
  - dimples for fingers
  - rubber to give extra grip
  - soft rubber is more comfortable to hold
  - plastic/rubber lightweight for holding.
- (b) (i) To make features stand out  
To make product 'eye catching'
- (ii) Any two of the following:
- different finishes (gloss/matt)
  - using a combination of different shapes
  - using a combination of different materials
  - using a combination of different styles/fashions
  - contrast/textures.
- (c) Customer survey/survey/market research/feedback/  
consumer test/poll/user trial
7. (a) Any two of the following:
- does not twist or warp
  - available in large sheets
  - defect free
  - cheaper than 'natural' wood
  - has a good surface to paint on
  - easy to work shape.

(b) Each must have sketch and label in correct position

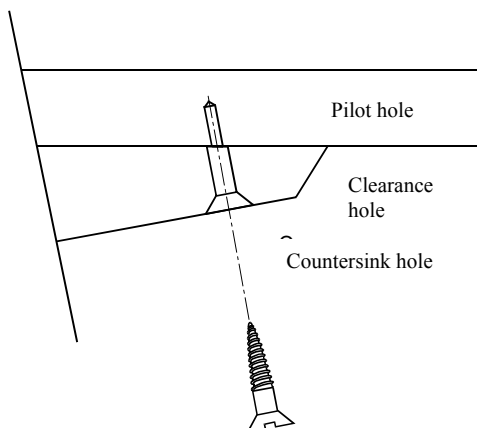

**Unacceptable answers**

- size
- size (on its own)
- sizes
- strong  
light  
environmentally friendly

[END OF MARKING INSTRUCTIONS]