

FOR OFFICIAL USE

--	--	--	--	--	--

G

Total

0600/402

NATIONAL
QUALIFICATIONS
2007

THURSDAY, 10 MAY
G/C 1.35 PM–2.35 PM
F/G 2.35 PM–3.35 PM

CRAFT AND DESIGN
STANDARD GRADE
General Level

Fill in these boxes and read what is printed below.

Full name of centre

Town

Forename(s)

Surname

Date of birth

Day Month Year

--	--	--	--	--	--	--	--

Scottish candidate number

--	--	--	--	--	--	--	--	--	--

Number of seat

- 1 Answer all the questions.
- 2 Read every question carefully before you answer.
- 3 Write your answers in the spaces provided.
- 4 Do **not** write in the margins.
- 5 All dimensions are given in millimetres.
- 6 Before leaving the examination room you must give this book to the invigilator. If you do not, you may lose all the marks for this paper.



ATTEMPT ALL QUESTIONS

1. A book stand made from wood is shown below.

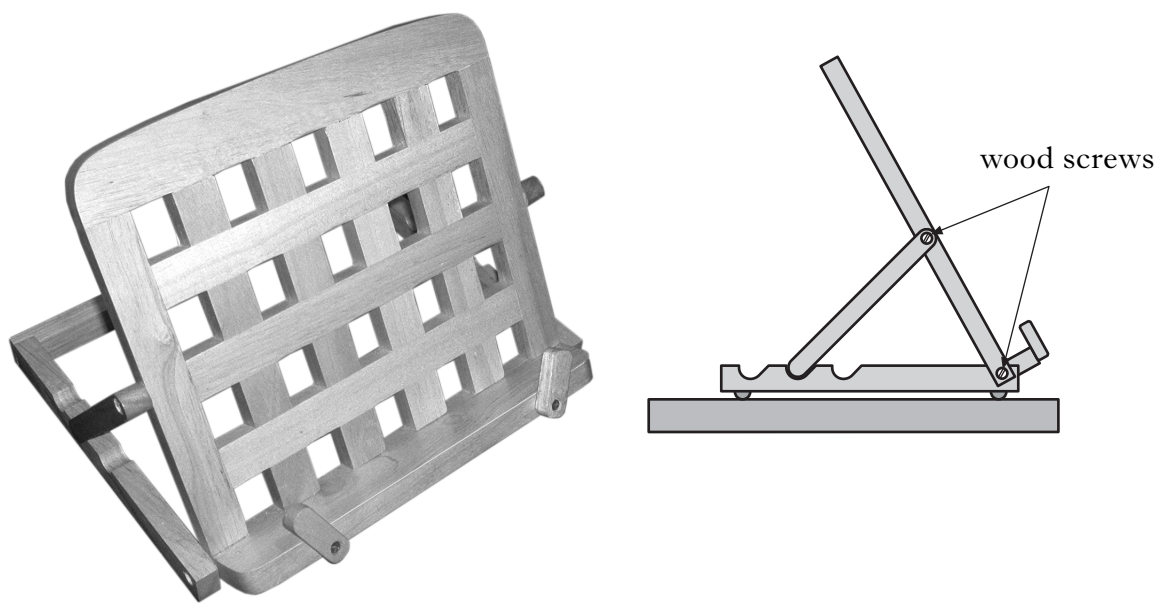

(a) State **one** feature of the stand that makes it suitable for use by a range of users.

1
0

(b) The wood joints shown below were used in the manufacture of the book stand. State the name of each joint.

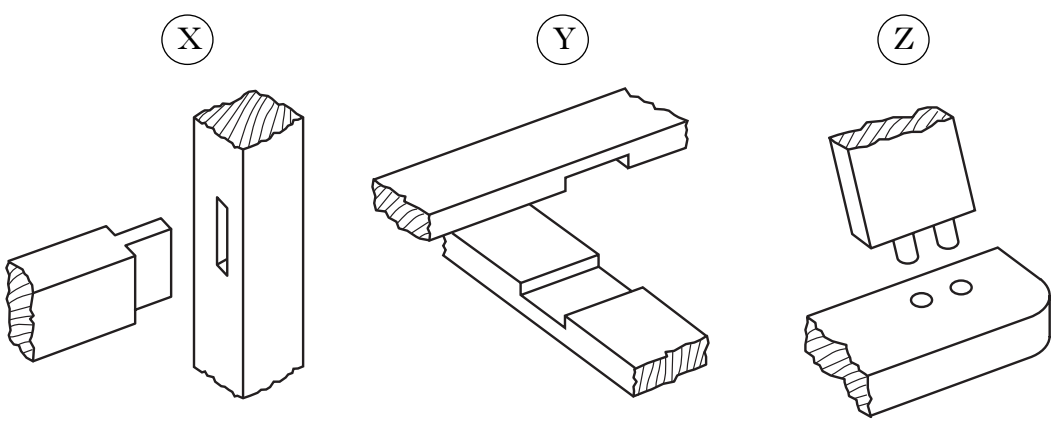

Joint X _____

Joint Y _____

Joint Z _____

1
0
1
0
1
0

1. (continued)

(c) The tool shown below was used during the manufacture of the book stand.

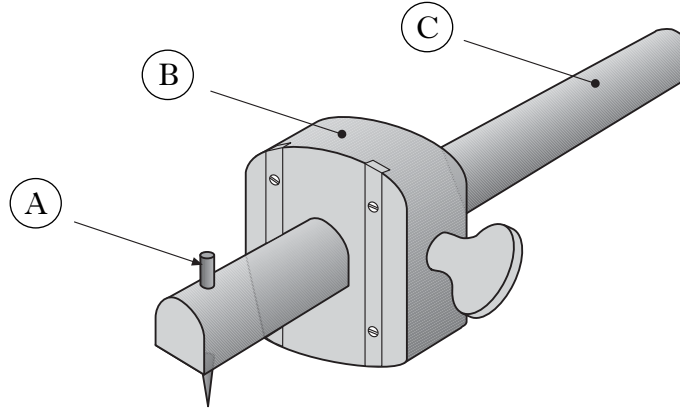

(i) State the name of this tool.

1
0

(ii) Select the name of the parts lettered (A), (B) and (C) from the list below.

Stock *Spur* *Stem* *Thumbscrew*

(A) _____

(B) _____

(C) _____

1
0
1
0
1
0

(d) The wood screw shown below was used in the manufacture of the book stand.

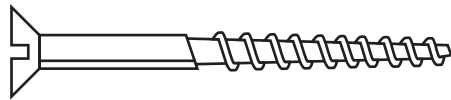

(i) State the name of this type of wood screw.

1
0

(ii) State **one** reason for using a wood screw with this type of head.

1
0

2. A pupil's design for a menu holder is shown below.

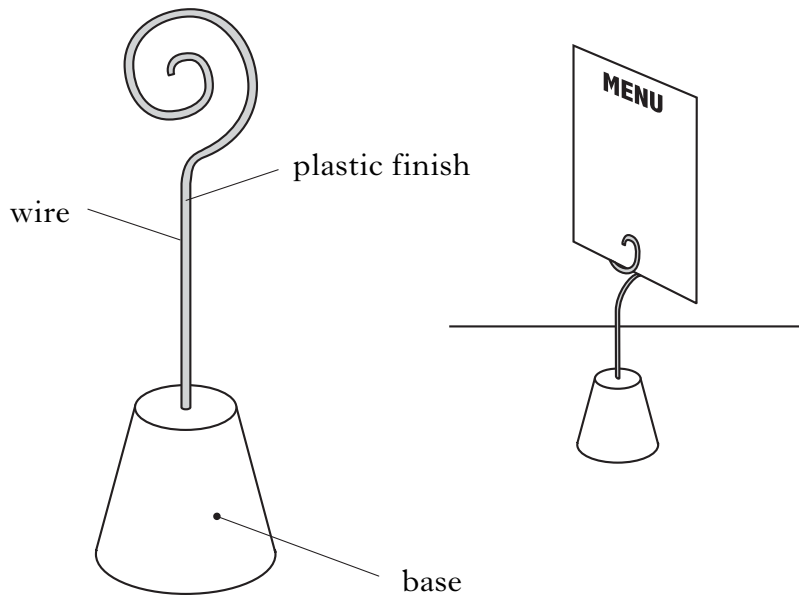

(a) The base was made from aluminium.

State **one** reason for this choice of material.

1
0

(b) (i) The base was made by a process of pouring molten aluminium into a sand mould.

Select the name of this process from the list below.

Forging

Casting

Welding

Turning

Name of process _____

1
0

2. (b) (continued)

A cross-section of the moulding boxes is shown below.

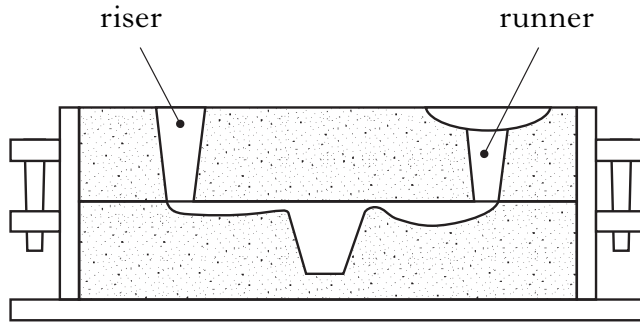

(ii) State the purpose of the runner and the riser.

Runner _____

Riser _____

1
0
1
0

(c) A protective plastic finish was applied to the wire.

(i) State the name of this process.

1
0

(ii) Several stages in the finishing process are listed in the **wrong** order.

allow metal to cool place metal in fluidiser heat metal in oven

clean metal with emery cloth

Arrange the stages in the correct order. The first one has been done for you.

1 Clean metal with emery cloth

2 _____

3 _____

4 _____

1
0
1
0
1
0

[Turn over

3. A pupil's design for a bedside unit is shown below.

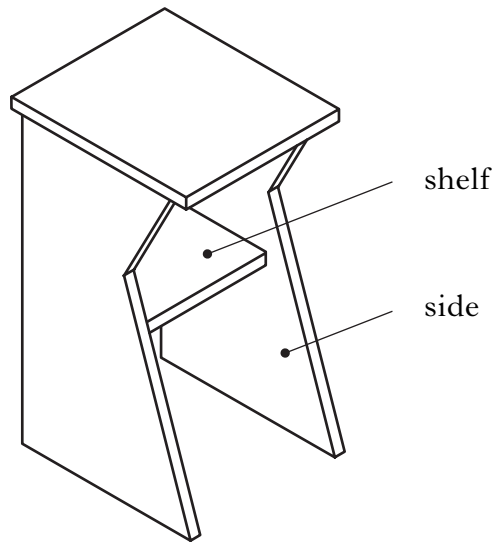

(a) The bedside unit is made from a manufactured board.

(i) State the name of a suitable manufactured board.

1
0

(ii) State **one** reason for using a manufactured board.

1
0

(b) The joint shown below was used to join the shelf to the sides.

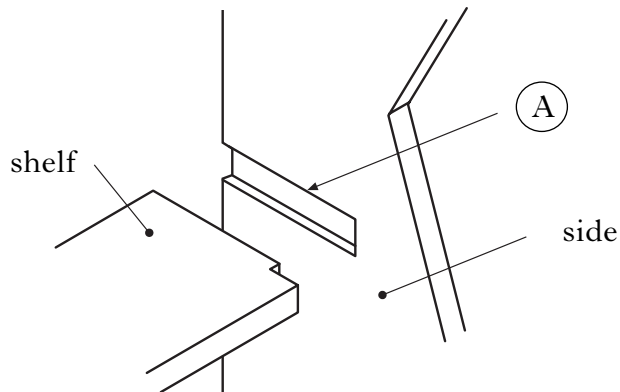

(i) State the name of this joint.

1
0

3. (b) (continued)

(ii) One stage in the manufacture of Part (A) of the joint is given below.

List **three** further stages.

1 mark out joint using try square and pencil.

2 _____

3 _____

4 _____

1
0

1
0

1
0

[Turn over

4. The specification and ideas for an egg holder are shown below.

Specification

- The holder must hold an egg securely
- The holder must be easy to clean
- The holder must have no sharp edges or corners
- The holder must be stable
- The holder must be made from one piece of plastic

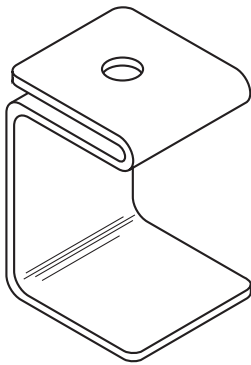

Idea 1

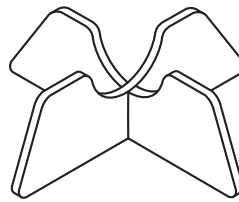

Idea 2

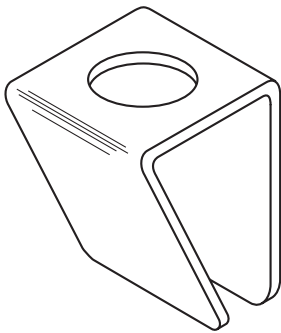

Idea 3

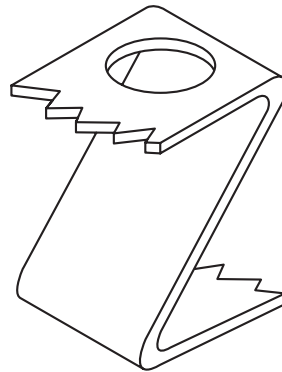

Idea 4



Idea 5

4. (continued)

- (a) After evaluation it was agreed that Idea 5 was the only one to meet the specification.

Ideas 1, 2, 3 and 4 did **not** meet the specification. State the reason why each idea failed.

Idea 1 _____

Idea 2 _____

Idea 3 _____

Idea 4 _____

1
0
1
0
1
0
1
0

- (b) During the design process eggs were measured.

The callipers shown below were used to measure eggs.

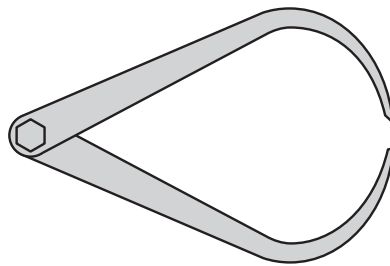

- (i) State the name of these callipers.

1
0

- (ii) State the stage in the design process when eggs would be measured.

1
0

- (c) During the design of the egg holder, models were made.

- (i) State a suitable material for modelling the egg holder.

1
0

- (ii) State **one** reason for your choice of material.

1
0

4. (continued)

(d) The final solution was made from plastic.

State **two** reasons why plastic is a good choice of material.

Reason 1 _____

Reason 2 _____

1
0
1
0

5. A guitar stand made from mild steel is shown below.

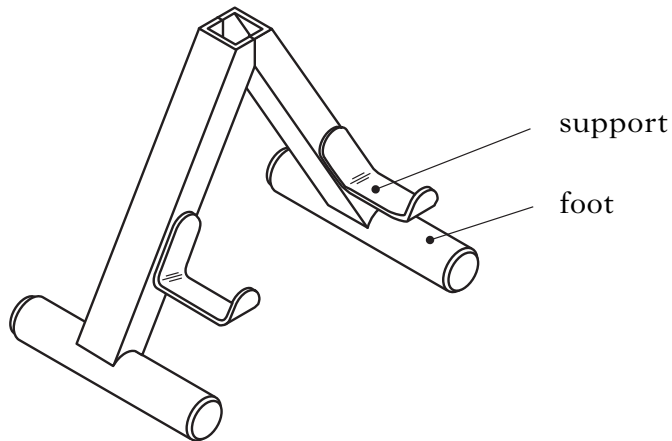

(a) The ends of the feet were turned on a metal lathe.

(i) State the name of the turning process shown below.

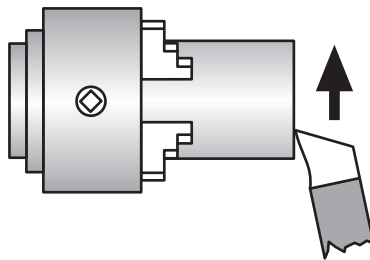

Name of turning process _____

1
0

(ii) The sharp edges at the ends of each foot were removed as shown below.

State the name of this turning process.

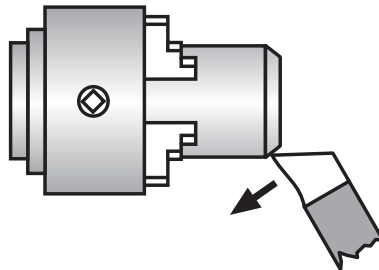

Name of turning process _____

1
0

[Turn over

5. (continued)

(b) Two safety precautions when using a metal lathe are given below.

State **two** further precautions.

1 Wear safety goggles

2 Tie up loose clothing and hair

3 _____

4 _____

1
0
1
0

(c) The supports were marked out using the tools shown.



State the name and purpose of each tool.

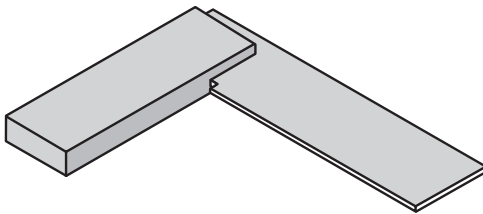

(i) Name _____

1
0

(ii) Purpose _____

1
0

5. (c) (continued)

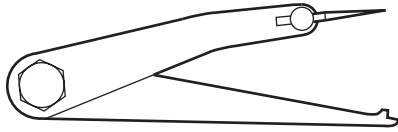

(iii) Name _____

1
0

(iv) Purpose _____

1
0



(v) Name _____

1
0

(vi) Purpose _____

1
0

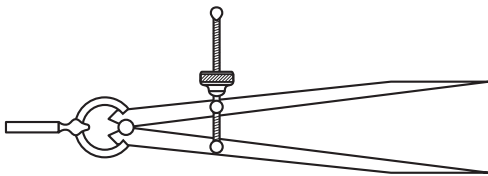

(vii) Name _____

1
0

(viii) Purpose _____

1
0

[Turn over

6. A school enterprise group made thermoplastic photo frames. An example is shown below.

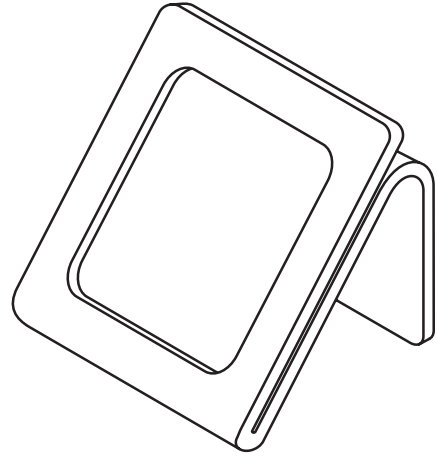

(a) State **one** reason for measuring the size of photographs during the design process.

1
0

(b) State the name of a suitable thermoplastic for the photo frame.

1
0

(c) The photo frame was marked out using a template as shown below.

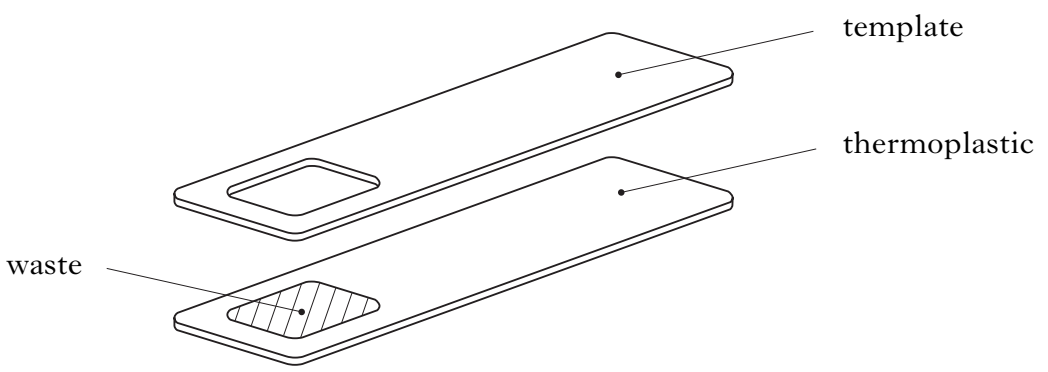

(i) State **one** reason for using a template.

1
0

(ii) Other than a pen or a pencil, state the name of a tool that could be used to mark the waste on the thermoplastic.

1
0

6. (continued)

(d) The machine and tools shown below were used during the manufacture of the picture frame.

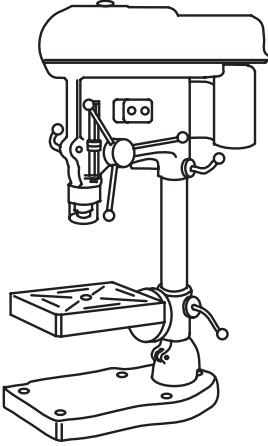

machine

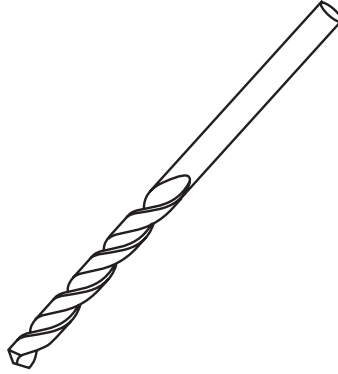

tool (1)

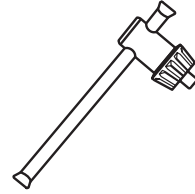

tool (2)

(i) State:

the name of the machine

1
0

the name of tool (1)

1
0

the name of tool (2)

1
0

the use of tool (2).

1
0

(ii) State **one** method that would stop the thermoplastic from cracking when it is drilled.

1
0

[Turn over for Question 6 (e), (f) and (g) on Page sixteen

6. (continued)

(e) The waste was removed using the saw shown below.

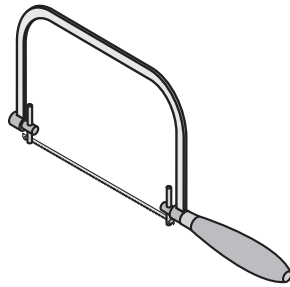

State the name of this saw.

1
0

(f) Two methods of filing were used when finishing the edges of the thermoplastic.

State the names of these two methods of filing.

Method 1 _____

Method 2 _____

1
0
1
0

(g) The machine shown below was used to heat the thermoplastic before bending.

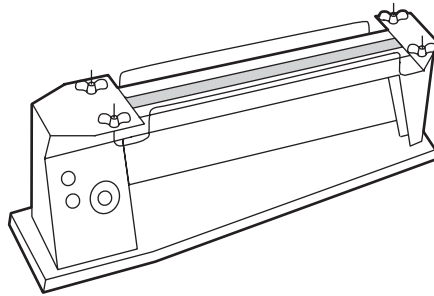

(i) State the name of this machine.

1
0

(ii) State what would happen to the thermoplastic if it was not hot enough before bending.

1
0

[END OF QUESTION PAPER]